

LID KEY	
2	GREEN COLOR

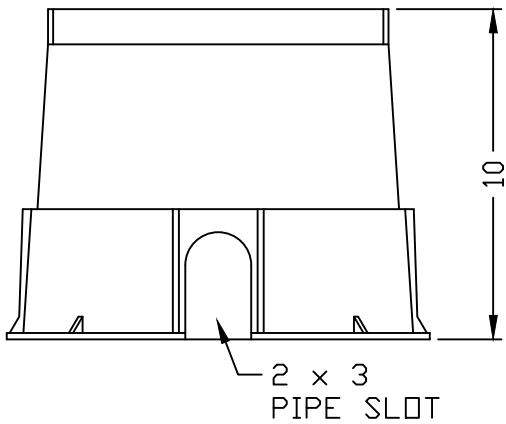

DFW1100.10.BODY

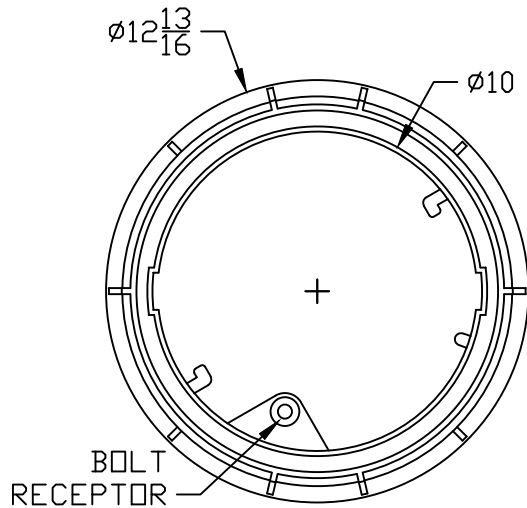
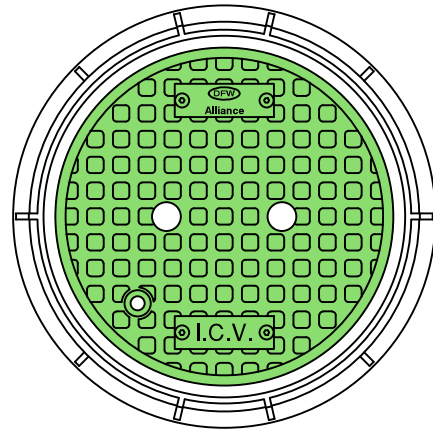

DFW1100.10.2

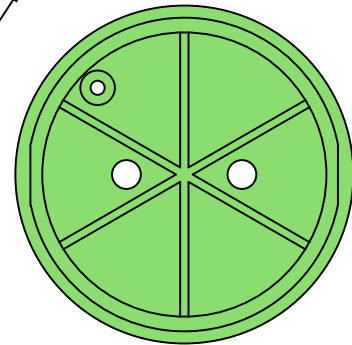
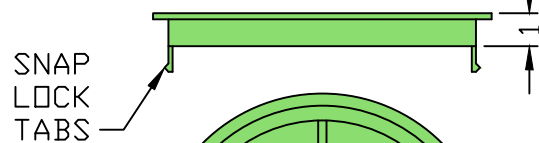
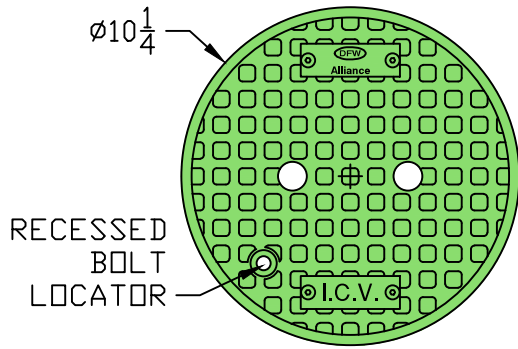

DFW1100.2.LID

NOTES

- 1) DIM'S $\pm 1/8$ U.N.O.
- 2) LID MATERIAL: POLYPROPYLENE
- 3) BODY MATERIAL: POLYPROPYLENE
- 4) WALL THICKNESS: $1/8" \pm 5\%$
- 5) I.W.A. = INSIDE WORK AREA

DFW PLASTICS, INC. ENGAGES IN ONGOING RESEARCH AND DEVELOPMENT TO IMPROVE AND ENHANCE ITS PRODUCTS. THEREFORE, DFW PLASTICS, INC. RESERVES THE RIGHT TO CHANGE PRODUCT OR SYSTEM SPECIFICATIONS WITHOUT NOTICE.



DFW PLASTICS, INC.
PO BOX 648
BEDFORD, TEXAS 76095
(817) 439-3600
(817) 439-3700 (f)
www.dfwplasticsinc.com

DFW1100.10.2

CREATED: 09/01/2010
UPDATED: 03/19/2014
ACCEPTED: JMc
DRAWN BY: RMc
PLOT SCALE: 1:4