

AMR
MOUNT
HOLES

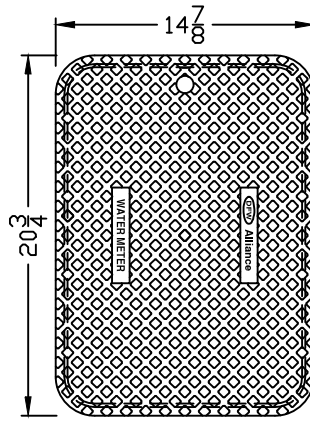

LID KEY	
1	BLACK COLOR

DFW1500.1.LID

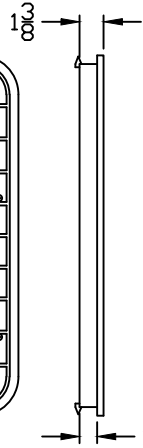
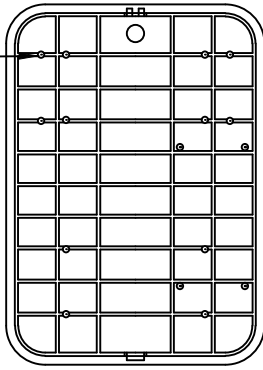
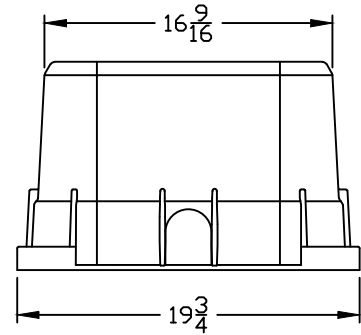
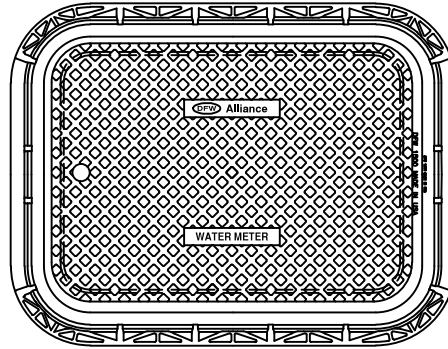
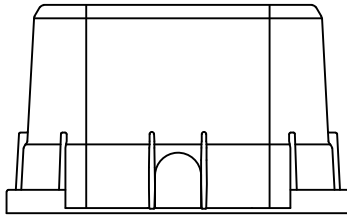

DFW1500TT.12.1

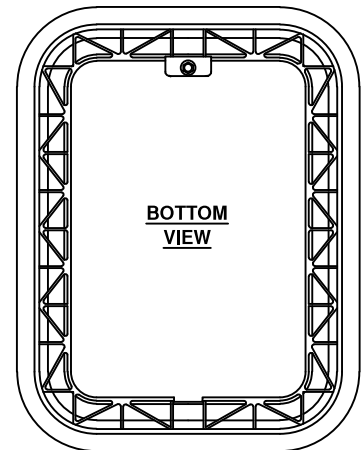
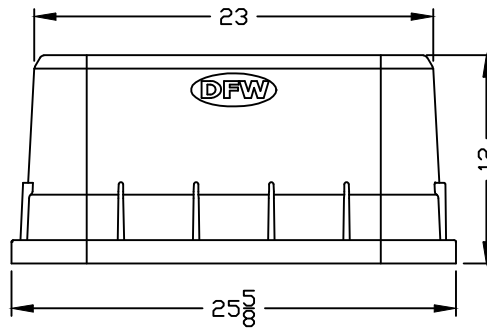
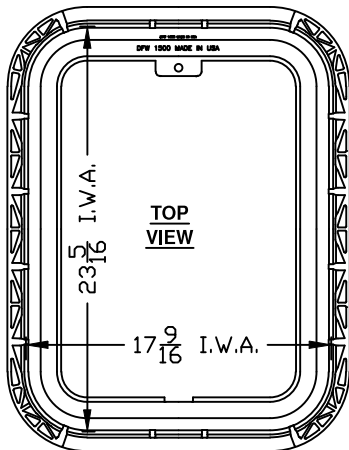

DFW1500TT.12.BODY

NOTES

- 1) DIM'S ± 1/8" U.N.O.
- 2) LID MATERIAL: POLYPROPYLENE
- 3) BODY MATERIAL: POLYPROPYLENE
- 4) WALL THICKNESS: 1/8" ± 5%
- 5) I.W.A. = INSIDE WORK AREA

DFW PLASTICS, INC. ENGAGES IN ONGOING RESEARCH AND DEVELOPMENT TO IMPROVE AND ENHANCE ITS PRODUCTS. THEREFORE, DFW PLASTICS, INC. RESERVES THE RIGHT TO CHANGE PRODUCT OR SYSTEM SPECIFICATIONS WITHOUT NOTICE.



DFW PLASTICS, INC.
PO BOX 648
BEDFORD, TEXAS 76095
(817) 439-3600
(817) 439-3700 (f)
www.dfwplasticsinc.com

DFW1500TT.12.1

CREATED: 07/15/2013

UPDATED: 03/20/2014

ACCEPTED: JMc

DRAWN BY: RMc

PLOT SCALE: 1:8