

BODY KEY	
X	DUAL IN, SINGLE OUT

LID KEY	
1	BLACK COLOR

DFW1200.1.LID

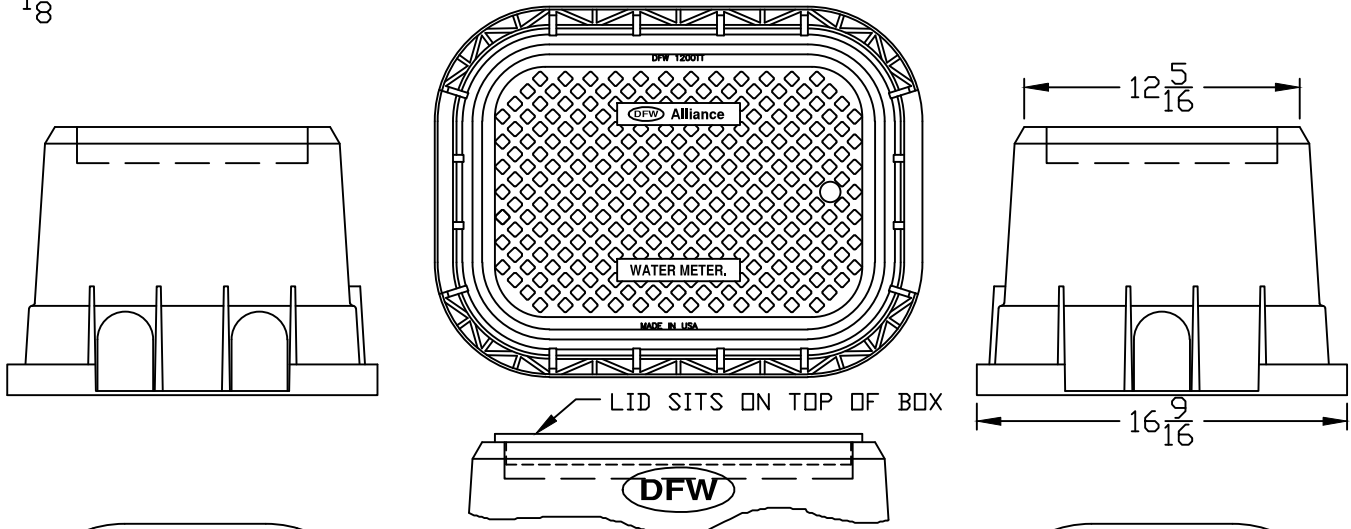

DFW1200TTX.12.1

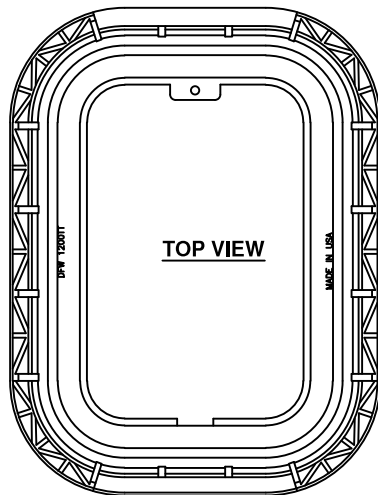

TOP VIEW

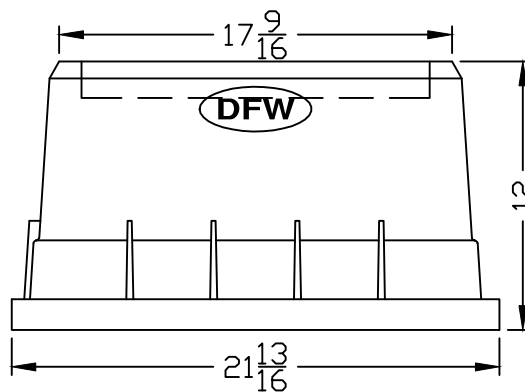

DFW

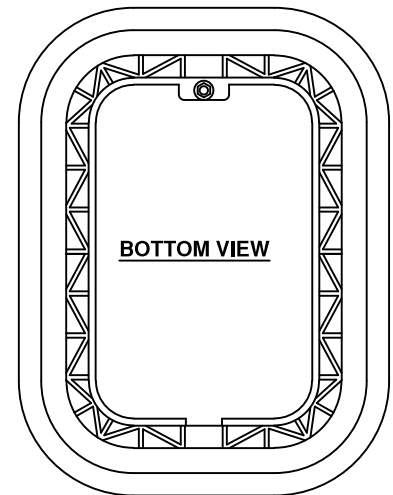

BOTTOM VIEW

DFW1200TTX.12.BODY

NOTES

- 1) DIM'S ± 1/8" U.N.O.
- 2) LID MATERIAL: POLYPROPYLENE
- 3) BODY MATERIAL: POLYPROPYLENE
- 4) WALL THICKNESS: 1/8" ± 5%
- 5) I.W.A. = INSIDE WORK AREA

DFW PLASTICS, INC. ENGAGES IN ONGOING RESEARCH AND DEVELOPMENT TO IMPROVE AND ENHANCE ITS PRODUCTS. THEREFORE, DFW PLASTICS, INC. RESERVES THE RIGHT TO CHANGE PRODUCT OR SYSTEM SPECIFICATIONS WITHOUT NOTICE.



DFW PLASTICS, INC.
 PO BOX 648
 BEDFORD, TEXAS 76095
 (817) 439-3600
 (817) 439-3700 (f)
 www.dfwplasticsinc.com

DFW1200TTX.12.1

CREATED: 07/15/2013
 UPDATED: 03/20/2014
 ACCEPTED: JMc
 DRAWN BY: RMc
 PLOT SCALE: 1:8